



3051047 Digital Speedometer Display



The 3051047 Digital Speedometer Display Module is used to remotely monitor vehicle speed on a three-digit 0.39" high LED 7-segment display.

The speedometer display receives vehicle wheel speed information from a standard J1939 communication network. The vehicle speed units of measure are user selectable using a front panel pushbutton switch.

The display brightness automatically adjusts to the optimal viewing level using an integral ambient light sensor. This allows the display to be fully readable in bright sunlight and nighttime driving conditions.

FEATURES

- Digital display of wheel-based vehicle speed
- Three digit, 0.39", high brightness red LEDs with automatic dimming
- SAE J1939 CAN with automatic baud rate detection (250K / 500K)
- Wide operating voltage range of 7 to 40 VDC ensures display operates during vehicle electrical system power disturbances
- Watertight DT04-4P Deutsch connector with 12" pigtail
- Low profile panel mount
- -40C to +85C (-40F to +185F) AEC-Q100 Grade 3 Operating Temperature

TECHNICAL SPECIFICATIONS

Operating Voltage	7 to 40 VDC
Current Consumption	145mA @ 12.8 VDC at max. display brightness
Operating Temperature	-40C TO +85C (-40F TO +185F)
Storage Temperature	-40C TO +85C (-40F TO +185F)
Ingress Protection	IP65
Electrical Protection	Reverse voltage polarity protection on power input Internal thermal fuses CAN Bus protected to 24V ESD protected to J1113-13 specifications Transient voltage protected to J1113-11 and J1113-42
CAN Interface	SAE J1939 CAN 2.0B port operating at 250K or 500K
Dimensions	1.80" X 3.58" X 1.80"

DIMENSIONS

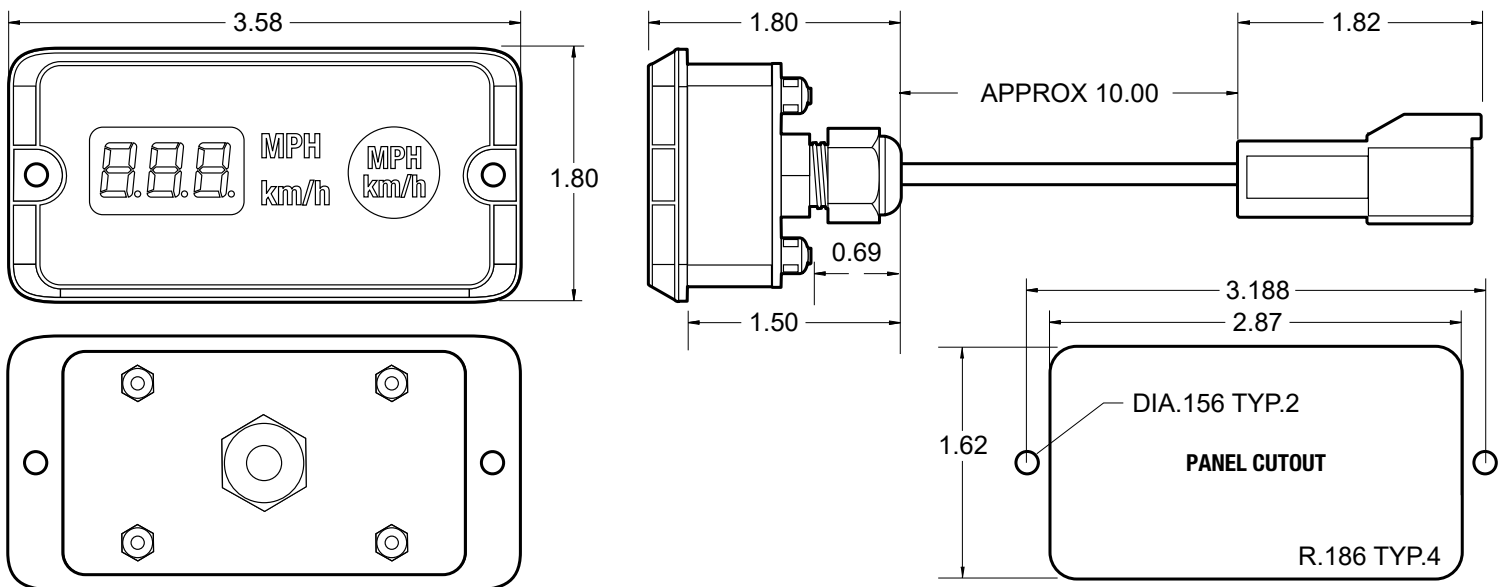

CONNECTOR PINOUT

CONNECTOR: POWER AND CAN DATA	PIN	DESCRIPTION
DEUTSCH DT04-4P	1	12VDC POWER
	2	GROUND
	3	CAN HIGH
	4	CAN LOW

Mating Connector is DT06-4S with W4S Wedgelock

CAN MESSAGE FORMAT

The digital speedometer displays data from J1939 SPN 84, Wheel Based Vehicle Speed from PGN 65265, Cruise Control/Vehicle Speed 1. PGN 65265 CAN message details are shown in the table below:

PGN 65265 CRUISE CONTROL / VEHICLE SPEED 1:	
CAN MESSAGE PARAMETER	VALUE
TRANSMISSION REPETITION RATE	100ms
PRIORITY	6
EXTENDED DATA PAGE	0
DATA PAGE	0
PDU FORMAT	254 (0xFE)
PDU SPECIFIC	241 (0xF1)
PGN	65265
DATA LENGTH	8
SOURCE ADDRESS	0 or 33 (0x00 or 0x21)

Speed of the vehicle as calculated from wheel or tail shaft speed.

SPN 84 WHEEL-BASED VEHICLE SPEED	
DATA LENGTH	2 BYTES*
RESOLUTION	1/256 km/h per bit, 0 offset
DATA RANGE	0 to 250.996 km/h
TYPE	MEASURED
PGN REFERENCE	65265

* If both data bytes are 0xFF the wheel speed measurement is interpreted as unavailable.

